

CATALOGO RICAMBI
SPARE PARTS CATALOGUE
CATALOGUE PIECES DETACHEES
ERSATZTEILKATALOG
CATALOGO PIEZAS DE REPUESTO

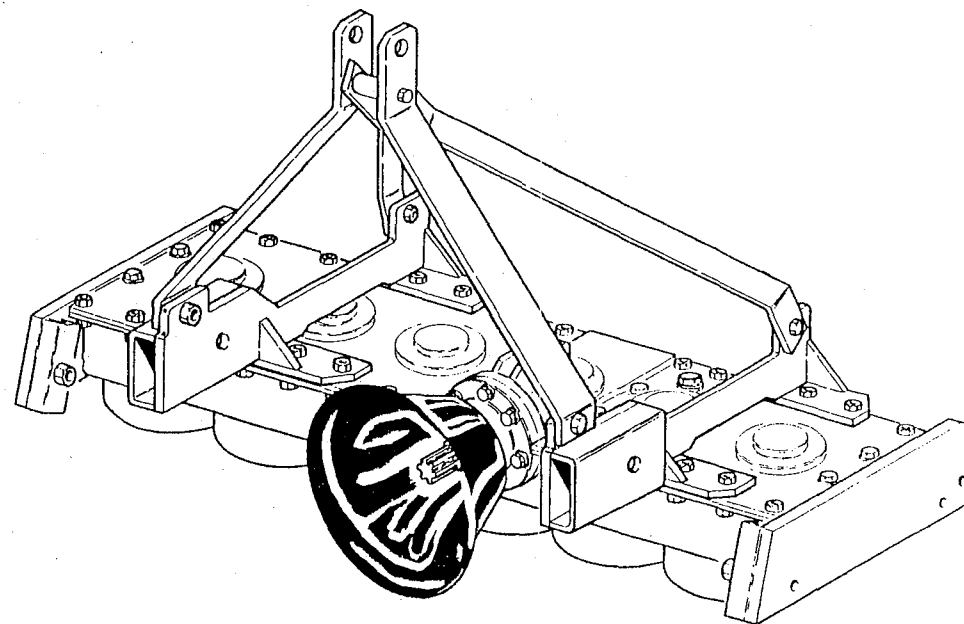

Mod. MTZ



COSTRUZIONI MECCANICHE

Via Valsellustra 25 - 29

40060 Toscanella di Dozza

Bologna (ITALY)

TEL.0039.0542.672100 FAX 0039.0542.674391

R2

COSTRUZIONI MECCANICHE

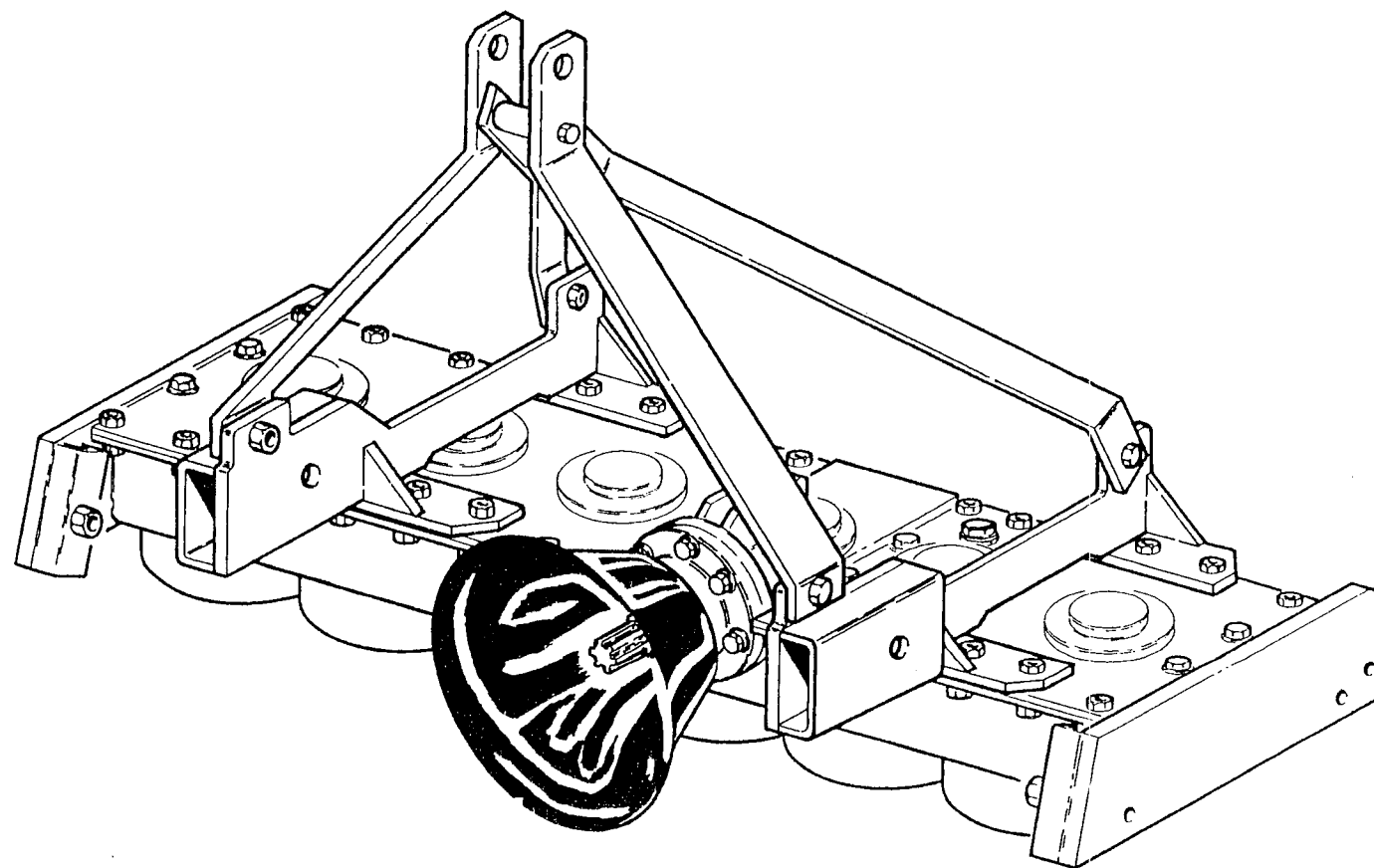

GRUPPO VASCA

BIN GROUP

GROUPE CUVE

WANNENAGGREGAT

GRUPO RECIPIENTE

MTZ 100 - 120

TAV-1



COSTRUZIONI MECCANICHE

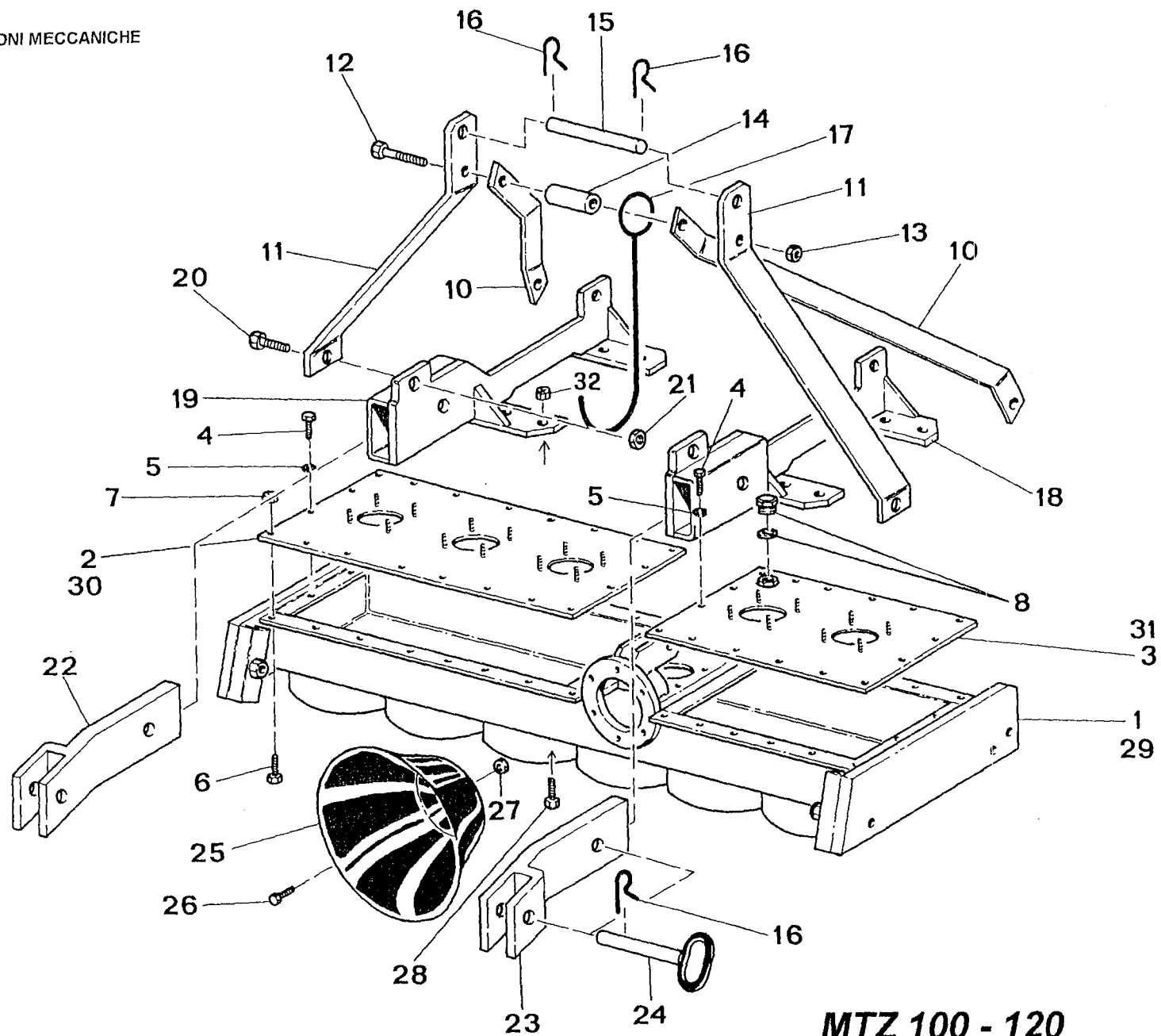

MTZ 100 - 120

TAV-1



COSTRUZIONI MECCANICHE

TAV-1

Nr	DESCRIZIONE DESCRIPTION DENOMINATION BEZEICHNUNG DESCRIPCION	CODICE PART N. CODE CODE CODIGO	QT.
----	--	---	-----

Nr	DESCRIZIONE DESCRIPTION DENOMINATION BEZEICHNUNG DESCRIPCION	CODICE PART N. CODE CODE CODIGO	QT.
----	--	---	-----

Nr	DESCRIZIONE DESCRIPTION DENOMINATION BEZEICHNUNG DESCRIPCION	CODICE PART N. CODE CODE CODIGO	QT.
----	--	---	-----

Mod. MTZ 120

1	Vasca 120 Frame 120 Chassis 120 Rahmen 120 Bastidor 120	034.004	1
2	Coperchio dx 120 Right cover 120 Couvercle droit 120 Abdeckung rechts 120 Tapa derecha 120	034.004/A	1
3	Coperchio sx 120 Left cover 120 Couvercle gauche 120 Abdeckung links 120 Tapa izquierda 120	034.004/B	1
4	Vite M8x20 Screw M8x20 Vis M8x20 Schraube M8x20 Tornillo M8x20	A398808020	8
5	Grover D 8 Grover D 8 Grover D 8 Grover D 8 Grover D 8	RONDGRI008	8
6	Vite M8x16 Screw M8x16 Vis M8x16 Schraube M8x16 Tornillo M8x16	A398808016	16
7	Dado autobloccante M8 Self-locking nut M8 Ecrou de sûreté M8 Selbstsichernde Mutter M8 Tuerca autobloccante M8	DA6S08MAAL	16

8	Tappo controllo livello olio Oil level control cap Bouchon contrôle de l'huile Ölstandspfropfen Tapón control nivel aceite	050.001	1
10	Lama posteriore Back blade Lame postérieure Hint. Verstrebung Hoja posterior	034.009	2
11	Lama anteriore Front blade Lame antérieure Vorderer Dreipunktbock Hoja anterior	034.008	2
12	Vite M12x90 Screw M12x90 Vis M12x90 Schraube M12x90 Tornillo M12x90	A378812090Z	1
13	Dado autobloccante M12 Self-locking nut M12 Ecrou de sûreté M12 Selbstsichernde Mutter M12 Tuerca autobloccante M12	DA6S12MAAL	1
14	Distanziale Spacer Entretoise Distanzstück Espaciador	034.012	1
15	Spinotto Pin Goujon Bolzen Perno	000.017	1

16	Coppiglia elastica Spring cotter Goupille Splint Pasador elastico	050.005	6
17	Gancio supp. cardano Cardan supp. hook Crochet supp. cardan Kardanhalterungshaken Gancho sop. cardan	034.019	1
18	Supporto att. trattore dx Tractor right connection support Supporto raccord tracteur droit Anschlußhalterung Traktor rechts Soporte enganche tractor derecho	034.011	1
19	Supporto att. trattore sx Tractor left connection support Supporto raccord tracteur gauche Anschlußhalterung Traktor links Soporte enganche tractor izquierdo	034.010	1
20	Vite M12x40 Screw M12x40 Vis M12x40 Schraube M12x40 Tornillo M12x40	A378812040Z	4
21	Dado autobloccante M12 Self-locking nut M12 Ecrou de sûreté M12 Selbstsichernde Mutter M12 Tuerca autobloccante M12	DA6S12MAAL	4
22	Braccio att. trattore sx Tractor left connection arm Bras raccord tracteur gauche Anschlußarm Traktor links Brazo enganche tractor izquierdo	000.015	1

R2

COSTRUZIONI MECCANICHE

Nr	DESCRIZIONE DESCRIPTION DENOMINATION BEZEICHNUNG DESCRIPCION	CODICE PART N. CODE CODE CODIGO	QT.
Mod. MTZ 120			
23	Braccio att.trattore dx Tractor right connection arm Bras raccord tracteur droit Anschlubarm Traktor rechts Brazo enganche tractor derecho	000.014	1
24	Spinotto Pin Goujon Bolzen Perno	000.016	4
25	Cuffia prot.cardano Cardan prot.cover Couverture prot.cardan Kardanschutzhäube Gorro de prot.cardàn	050.052	1
26	Vite M8x20 Screw M8x20 Vis M8x20 Schraube M8x20 Tornillo M8x20	A398808020Z	3
27	Dado autobloccante M8 Self-locking nut M8 Ecrou de sûreté M8 Selbstsichernde Mutter M8 Tuerca autoblocante M8	DA6S08MAAL	3
28	Vite M10x30 Screw M10x30 Vis M10x30 Schraube M10x30 Tornillo M10x30	A378810030	12
32	Dado autobloccante M10 Self-locking nut M10 Ecrou de sûreté M10 Selbstsichernde Mutter M10 Tuerca autoblocante M10	DA6S10MAAL	12

Nr	DESCRIZIONE DESCRIPTION DENOMINATION BEZEICHNUNG DESCRIPCION	CODICE PART N. CODE CODE CODIGO	QT.
Mod. MTZ 100			
29	Telaio 90 Frame 90 Châssis 90 Rahmen 90 Bastidor 90	031.049	1
30	Coperchio dx 90 Right cover 90 Couvercle droit 90 Deckel rechts 90 Tapa derecha 90	031.049/A	1
31	Coperchio sx 90 Left cover 90 Couvercle gauche 90 Deckel links 90 Tapa izquierda 90	031.049/B	1

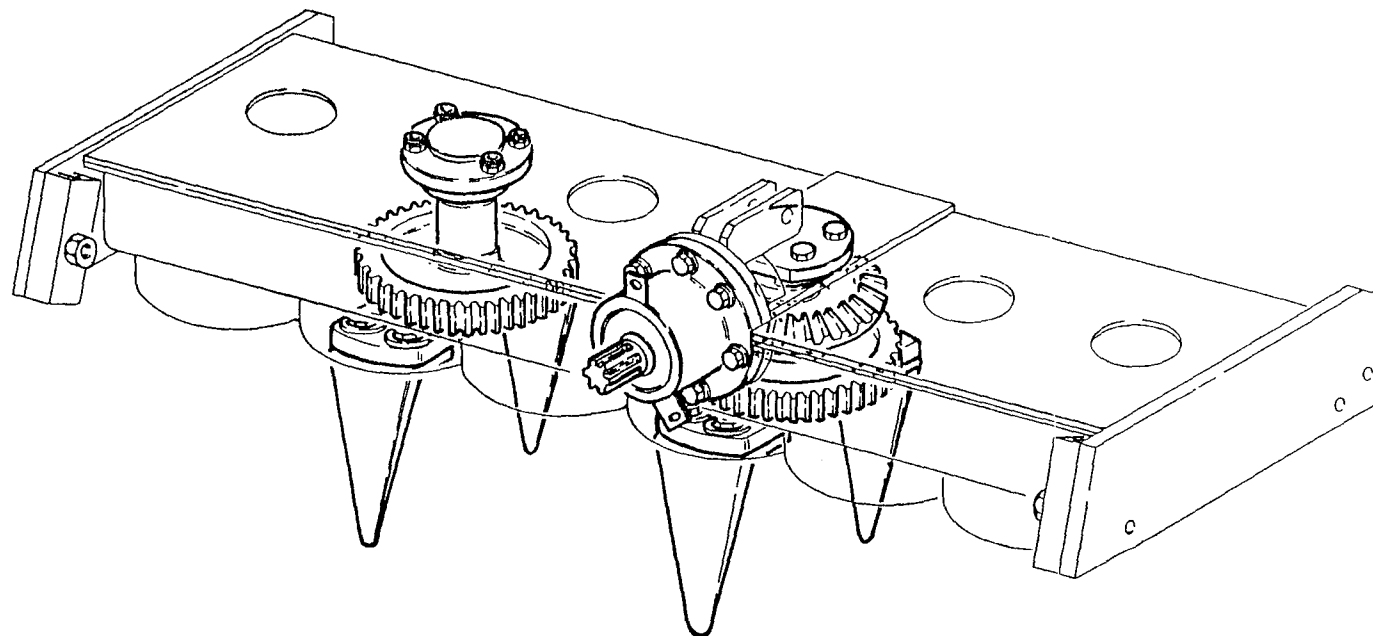

GRUPPO FORCELLE PORTA ZAPPE

HOES FORK GROUP

GROUPE FOURCHES PORTE-HOUES

GRUPPE ZINKENHALTERGABELN

GRUPO HORQUILLAS PORTA-AZADAS

MTZ 100 - 120

TAV-2

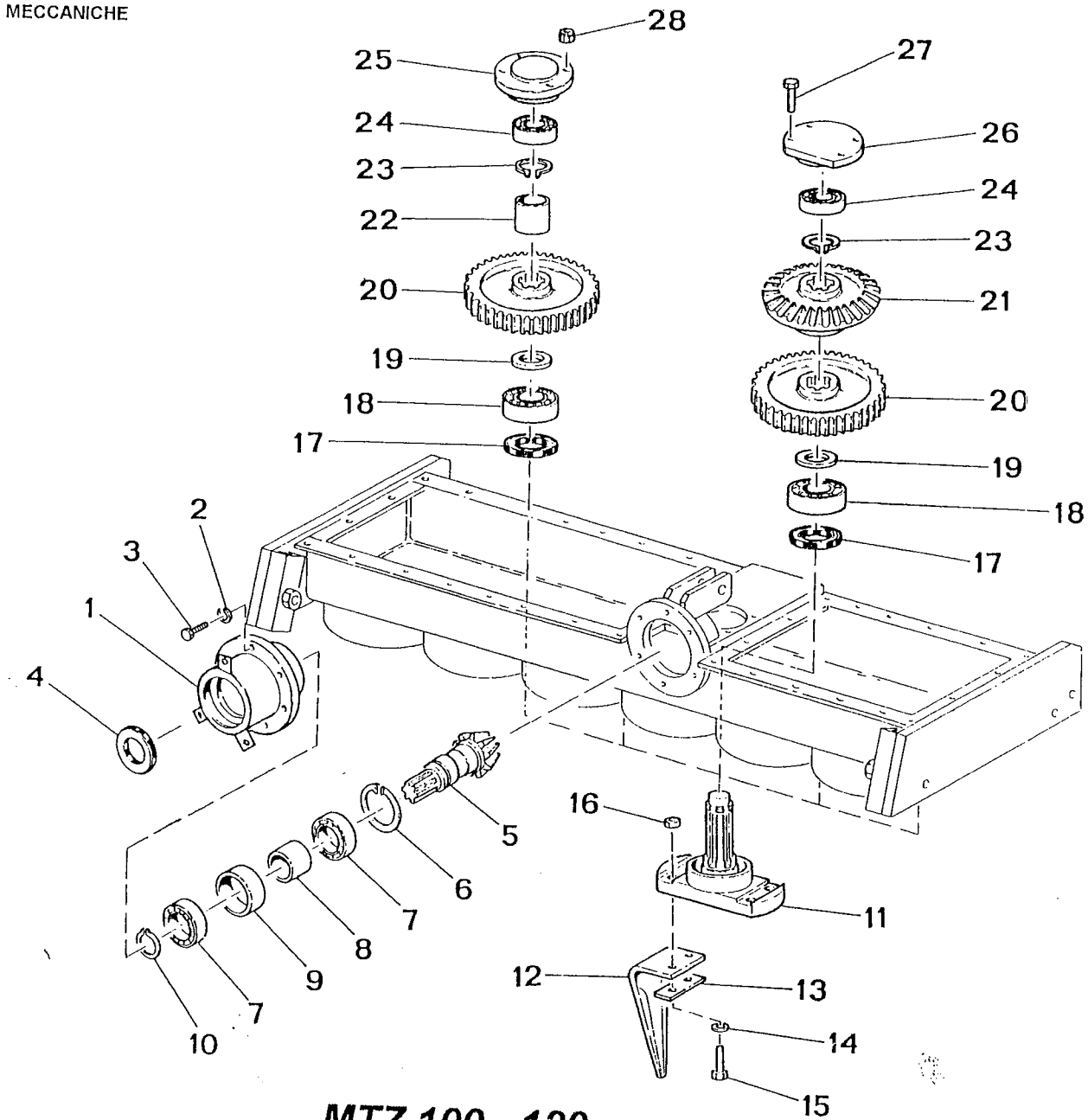

MTZ 100 - 120

R2

COSTRUZIONI MECCANICHE

TAV-2

Nr.	DESCRIZIONE DESCRIPTION DENOMINATION BEZEICHNUNG DESCRIPCION	CODICE PART N. CODE CODE CODIGO	QT.
-----	--	---	-----

Nr.	DESCRIZIONE DESCRIPTION DENOMINATION BEZEICHNUNG DESCRIPCION	CODICE PART N. CODE CODE CODIGO	QT.
-----	--	---	-----

Nr.	DESCRIZIONE DESCRIPTION DENOMINATION BEZEICHNUNG DESCRIPCION	CODICE PART N. CODE CODE CODIGO	QT.
-----	--	---	-----

Mod. MTZ 120

1	Mozzo porta pignone Pinion hub Moyeu porte-pignon Ritzelnabe Cubo portapiñón	034.003	1
2	Grover D.8 Grover D.8 Grover D.8 Grover D.8 Grover D.8	RONDGR1008	6
3	Vite M8x25 Screw M8x25 Vis M8x25 Schraube M8x25 Tornillo M8x25	A398808025	6
4	Paraolio 30.62.7 Oil seal 30.62.7 Pare-huile 30.62.7 Ölabdichtung 30.62.7 Guardagotas 30.62.7	D30627	1
5	Pignone Pinion Pignon Ritzel Piñón	034.002	1
6	Seeger D.72 Seeger D.72 Seeger D.72 Seeger D.72 Seeger D.72	AEINS47272	1
7	Cuscinetto 6207 Bearing 6207 Roulement 6207 Lager 6207 Cojinete 6207	A6207 II	2

8	Distanziale Spacer Entretoise Distanzstück Espaciador	031.045	1
9	Distanziale Spacer Entretoise Distanzstück Espaciador	031.046	1
10	Seeger D.35 Seeger D.35 Seeger D.35 Seeger D.35 Seeger D.35	AEESS47135	1
11	Forcella porta zappa Hoe fork Fourche porte-houe Zinkenhalterungsgabel Horquilla porta-azada	031.033	6
12	Zappa Hoe Houe Zinken Azada	000.010	12
13	Piastrino di bloccaggio Locking plate Plaquette de blocage Feststellblech Placa de bloqueo	000.002	12
14	Grover D.10 Grover D.10 Grover D.10 Grover D.10 Grover D.10	RONDGRI010	24

15	Vite M10x1,25x45 Screw M10x1,25x45 Vis M10x1,25x45 Schraube M10x1,25x45 Tornillo M10x1,25x45	A388810045	24
16	Dado autobloccante M10x1,25 Self-locking nut M10x1,25 Ecrou de sùreté M10x1,25 Selbstsichernde Mutter M10x1,25 Tuerca autobloccante M10x1,25	DA6S10MBAL	24
17	Paraolio 40.58.10 TGP Oil seal 40.58.10 TGP Pare-huile 40.58.10 TGP Ölabdichtung 40.58.10 TGP Guardagotas 40.58.10 TGP	D 405810 TGP	6
18	Cuscinetto 6207 Bearing 6207 Roulement 6207 Lager 6207 Cojinete 6207	A6207 II	6
19	Distanziale Spacer Entretoise Distanzstück Espaciador	031.041	6
20	Ingranaggio Gear Engranaage Zahnrad Engranaje	031.005	6
21	Corona Crown Couronne Zahnkranz Corona	034.001	1

R2

COSTRUZIONI MECCANICHE

TAV-2

Nr.	DESCRIZIONE DESCRIPTION DENOMINATION BEZEICHNUNG DESCRIPCION	CODICE PART N. CODE CODE CODIGO	QT.
-----	--	---	-----

Nr.	DESCRIZIONE DESCRIPTION DENOMINATION BEZEICHNUNG DESCRIPCION	CODICE PART N. CODE CODE CODIGO	QT.
-----	--	---	-----

Nr.	DESCRIZIONE DESCRIPTION DENOMINATION BEZEICHNUNG DESCRIPCION	CODICE PART N. CODE CODE CODIGO	QT.
-----	--	---	-----

Mod. MTZ 120

Mod. MTZ 100

22	Distanziale Spacer Entretoise Distanzstück Espaciador	000.012	5
23	Seeger D.30 Seeger D.30 Seeger D.30 Seeger D.30 Seeger D.30	AEESS47130	6
24	Cuscinetto 6205 Bearing 6205 Roulement 6205 Lager 6205 Cojinete	A6205 II	6
25	Coperchietto laterale Side cover Couvercle latéral Kleiner seitl. Deckel Tapa lateral	031.010	5
26	Coperchietto centrale Central cover Couvercle centrale Kleiner zentraler Deckel Tapa central	031.009	1
27	Vite M8x16 Screw M8x16 Vis M8x16 Schraube M8x16 Tornillo M8x16	A398808016	4
28	Dado autobloccante M8 Self-locking nut M8 Ecrou de sùreté M8 Selbstsichernde Mutter M8 Tuerca autoblocante M8	DA6S08MAAL	20

1	Mozzo porta pignone Pinion hub Moyeu porte-pignon Ritzelnabe Cubo portapiñón	034.003	1
2	Grover D.8 Grover D.8 Grover D.8 Grover D.8 Grover D.8	RONDGR1008	6
3	Vite M8x25 Screw M8x25 Vis M8x25 Schraube M8x25 Tornillo M8x25	A398808025	6
4	Paraolio 30.62.7 Oil seal 30.62.7 Pare-huile 30.62.7 Ólabdichtung 30.62.7 Guardagotas 30.62.7	D30627	1
5	Pignone Pinion Pignon Ritzel Piñón	034.002	1
6	Seeger D.72 Seeger D.72 Seeger D.72 Seeger D.72 Seeger D.72	AEINS47272	1
7	Cuscinetto 6207 Bearing 6207 Roulement 6207 Lager 6207 Cojinete 6207	A6207 II	2

8	Distanziale Spacer Entretoise Distanzstück Espaciador	031.045	1
9	Distanziale Spacer Entretoise Distanzstück Espaciador	031.046	1
10	Seeger D.35 Seeger D.35 Seeger D.35 Seeger D.35 Seeger D.35	AEESS47135	1
11	Forcella porta zappa Hoe fork Fourche porte-houe Zinkenhalterungsgabel Horquilla porta-azada	031.033	5
12	Zappa Hoe Houe Zinken Azada	000.010	10
13	Piastrino di bloccaggio Locking plate Plaque de blocage Feststellblech Placa de bloqueo	000.002	10
14	Grover D.10 Grover D.10 Grover D.10 Grover D.10 Grover D.10	RONDGR1010	20

R2

COSTRUZIONI MECCANICHE

Nr.	DESCRIZIONE DESCRIPTION DENOMINATION BEZEICHNUNG DESCRIPCION	CODICE PART N. CODE CODE CODIGO	QT.
-----	--	---	-----

Nr.	DESCRIZIONE DESCRIPTION DENOMINATION BEZEICHNUNG DESCRIPCION	CODICE PART N. CODE CODE CODIGO	QT.
-----	--	---	-----

Mod. MTZ 100

15	Vite M10x1,25x45 Screw M10x1,25x45 Vis M10x1,25x45 Schraube M10x1,25x45 Tornillo M10x1,25x45	A388810045	20
16	Dado autobloccante M10x1,25 Self-locking nut M10x1,25 Ecrou de sùrété M10x1,25 Selbstsichernde Mutter M10x1,25 Tuerca autoblocante M10x1,25	DA6S10MBAL	20
17	Paraolio 40.58.10 TGP Oil seal 40.58.10 TGP Pare-huile 40.58.10 TGP Ölabdichtung 40.58.10 TGP Guardagotas 40.58.10 TGP	D 405810 TGP	5
18	Cuscinetto 6207 Bearing 6207 Roulement 6207 Lager 6207 Cojinete 6207	A6207 II	5
19	Distanziale Spacer Entretoise Distanzstück Espaciador	031.041	5
20	Ingranaggio Gear Engranage Zahnrad Engranaje	031.005	5
21	Corona Crown Couronne Zahnkranz Corona	034.001	1

22	Distanziale Spacer Entretoise Distanzstück Espaciador	000.012	4
23	Seeger D.30 Seeger D.30 Seeger D.30 Seeger D.30	AEESS47130	5
24	Cuscinetto 6205 Bearing 6205 Roulement 6205 Lager 6205 Cojinete 6205	A6205 II	5
25	Coperchietto laterale Side cover Couvercle latéral Kleiner seiti. Deckel Tapa lateral	031.010	4
26	Coperchietto centrale Central cover Couvercle centrale Kleiner zentraler Deckel Tapa central	031.009	1
27	Vite M8x16 Screw M8x16 Vis M8x16 Schraube M8x16 Tornillo M8x16	A398808016	4
28	Dado autobloccante M8 Self-locking nut M8 Ecrou de sùrété M8 Selbstsichernde Mutter M8 Tuerca autoblocante M8	DA6S08MAAL	16

